

TABLE 1: ELECTRICAL SPECIFICATIONS AT 25 °C

PARAMETER	SPEC LIMITS			UNITS
	MIN.	TYP.	MAX.	
TURNS RATIO'S: FREQUENCY: 10 KHZ VOLTAGE: 1.0 VRMS 1-3 (11-13) : 4-8 (14-18) 1-3 (11-13) : 5-7 (15-17)	-----	1 : 2.50	-----	± 3%
DC RESISTANCE 1-3, 11-13 4-8, 14-18	-----	-----	1.0 3.5	Ω
IMPEDANCE:4-8, 14-18 FREQUENCY: 75 KHZ TO 1.0 MHZ	4000	-----	-----	Ω
COMMON MODE REJECTION	45	-----	-----	dB
HI-POT: BETWEEN 1 to 4 & 11 to 14	100	-----	-----	VRMS
INSULATION RESISTANCE (250VDC) BETWEEN 1 to 4 & 11 to 14	1000	-----	-----	MΩ

NOTE1:
MEET MIL-STD-1553 AND MIL-T-21038 ELECTRICAL CHARACTERISTICS.

FIGURE 2: PHYSICAL DIMENSIONS IN INCHES (mm)

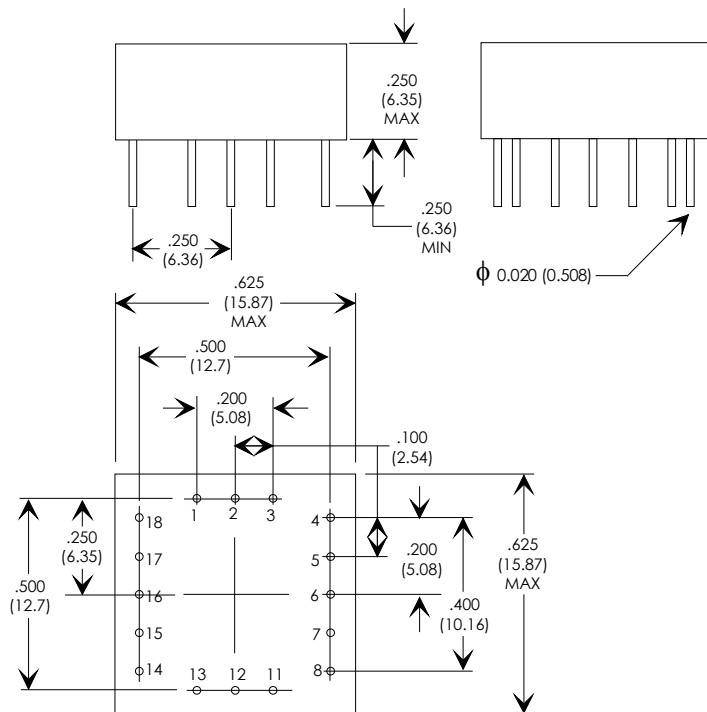
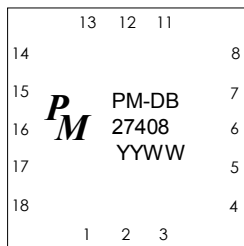
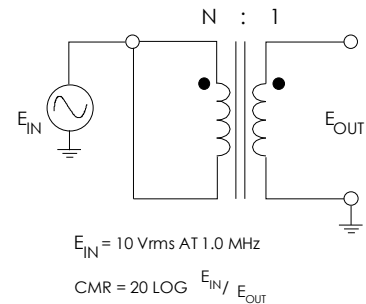
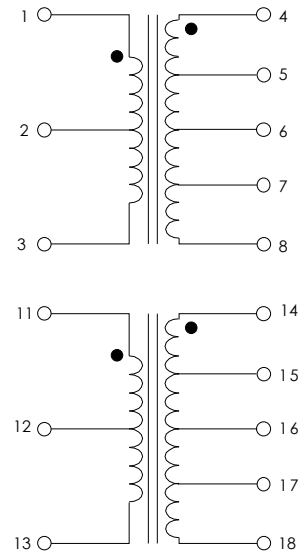

FIGURE 1: SCHEMATIC DIAGRAM



REV.	DESCRIPTION OF CHANGES	BY
05/01/03	ORIGINAL RELEASE	PP
11/18/04	ADD DIMENSION TO CENTER 1-3 & 11-13	PP
12/01/04	CORRECT THE CORE VENDOR	PP
05/16/07	CHANGE THE PIN LENGTH	PP
09/10/09	ADD GENERAL SPECIFICATION TABLE ON PAGE 2	PP



UNLESS OTHERWISE SPECIFIED
DIMENSIONS ARE IN INCHES
DIMENSIONAL TOLERANCES ARE:
DECIMALS ANGLES
.XX ± .04 ± 0° 30'
.XXX ± .020
DO NOT SCALE DRAWING

TRANSFORMER CONTROL DRAWING	
PREMIER P/N: PM-DB27408	REVISION: 09/10/09
ENGR: PETER PHAM	REF:
SCALE: NONE	SHEET: 1 OF 2

TABLE 2: GENERAL SPECIFICATIONS

PARAMETER	VALUE	UNIT	REMARKS
Case			Flame Resistant, Diallyl Phthalate
Weight	gm	5 Max	
Terminals			Solderable
Terminal Strength	lbs	2	2 pounds applied force, Mil-Std-202, Method 211, Condition A
Dielectric Withstanding Voltage	Vrms	100	Mil-Std-202, Method 301
Insulation Resistance	MΩ	1,000	Mil-Std-202, Method 302, Condition B, At 250Vdc
Life (Expectancy "X")	Hrs	10,000 Min	Mil-Prf-21038
Pulse Width	μS	2	Mil-Prf-21038, Figure 3 & 4
Overshoot & Ringing	V	± 1 Max	Mil-Prf-21038, Figure 3 & 4
Droop	%	20%Max	Mil-Prf-21038, Figure 3 & 4
Rise Time	ns	150 Max	Mil-Prf-21038, Figure 3 & 4
Common Mode Rejection	dB	45	Mil-Prf-21038, Figure 2
Operation Temperature	°C	-55°C to +130°C	
Turns Ratio			See Table 1
DC Resistance			See Table 1
Impedance			See Table 1



UNLESS OTHERWISE SPECIFIED
 DIMENSIONS ARE IN INCHES
 DIMENSIONAL TOLERANCES ARE:
 DECIMALS ANGLES
 .XX ± .04 ± 0° 30'
 .XXX ± .020
 DO NOT SCALE DRAWING

TRANSFORMER CONTROL DRAWING

PREMIER P/N: PM-DB27408	REVISION: 09/10/09
ENGR: PETER PHAM	REF:
SCALE: NONE	SHEET: 2 OF 2

