

Mechanical:

REV.	ECN NO.	DESCRIPTION	DATE	APPD
A	REL		2007-11-30	

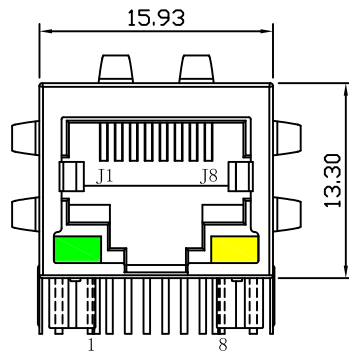

Front Side View

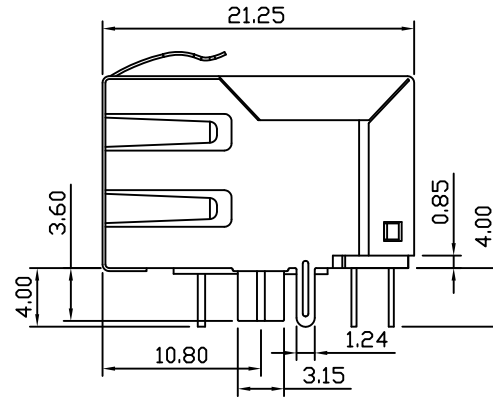

Left Side View

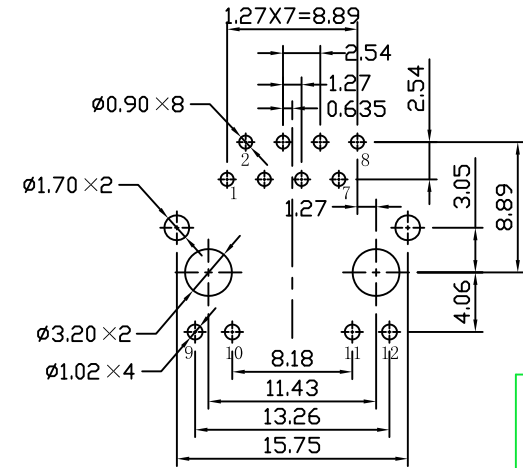

Suggested PCB Layout (Top View)

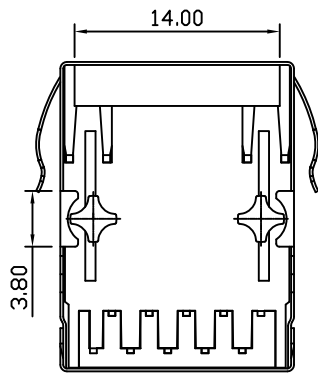

Bottom Side View

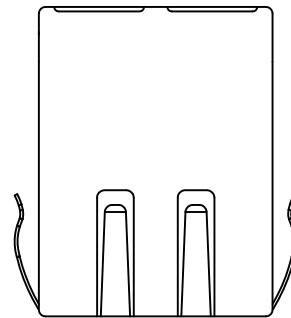

Top Side View

NOTES:

1. Designed to support application, such as SOHO (ADSL modems), LAN-on-Motherboard (LOM), hub and Switches.
2. Meets IEEE 802.3 specification
3. Connector Materials:
 Housing: Thermoplastic PBT+30%G.F UL94V-0
 Contact: Phosphor Bronze C5210R-EH Thickness=0.35mm
 Pins: Brass C2680R-H Thickness=0.35mm
 Shield: SUS 201-1/2H Thickness=0.2mm
 Contact plating: Gold 6 micro-inches min. In contact area.
4. Wave solder tip temperature: 265°C Max, 5 Sec.

X:X	±0.25	APPD:	
X:XX	±0.20	CHKD:	
X:XXX	±0.05	DR: SEA	TITLE: RJ45 Connector with 10/100 Base-T Integrated Magnetics
ANGLES	±1°	UNIT: mm	PART NO.: KLK0011GENL
	SCALE: 2/1	SHEET: 1/4	REV: A DWG NO.:

Schematic:

REV.	ECN NO.	DESCRIPTION	DATE	APPD
A	REL		2007-11-30	

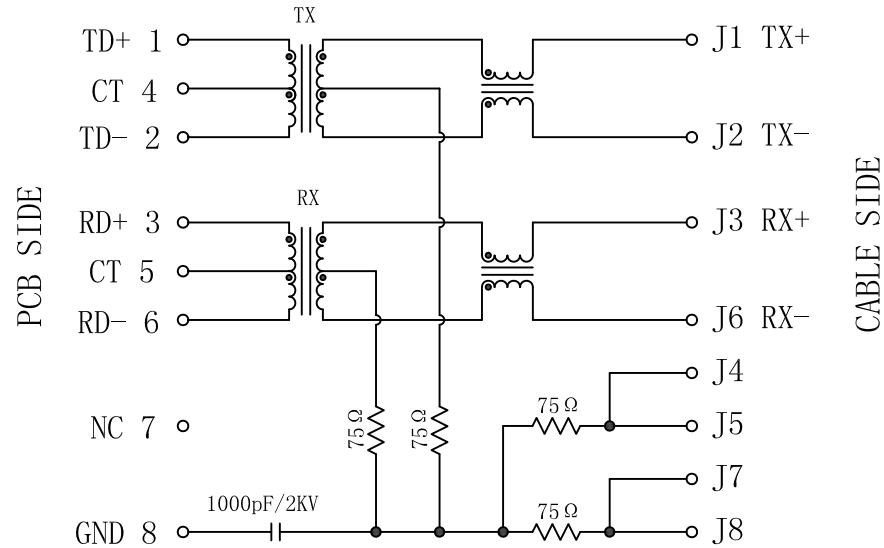

CABLE SIDE

ELECTRICAL SPECIFICATIONS @25°C

- Turn Ratio ($\pm 3\%$):
TX=1CT : 1CT RX=1CT : 1CT
- Inductance OCL: 350uH MIN
@100KHz 0.1V 8mA DC Bias
- Insertion Loss:
-1.0dB MAX @1-65MHz
- Return Loss:
-20dB MIN @1-10MHz
-16dB MIN @10-30MHz
-12dB MIN @30-60MHz
-10dB MIN @60-100MHz
- Cross talk:
-40dB MIN @1-30MHz
-35dB MIN @30-60MHz
-30dB MIN @60-100MHz
- Common Mode Rejection:
-30dB MIN @1-50MHz
-20dB MIN @50-150MHz
- Hipot Test: 1500Vrms
- Operating Temperature Range: 0°C TO 70°C

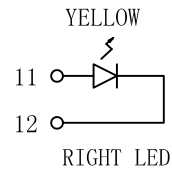
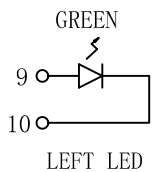

Emitting Color	λ_p (nm)	V _F @I _F =20mA	I _R @V _R =5V
GREEN	565	1.8~2.6V	10 μ A max
YELLOW	585	1.8~2.6V	10 μ A max

X:X	± 0.25	APPD:	
X:XX	± 0.20	CHKD:	
X:XXX	± 0.05	DR: SEA	TITLE: RJ45 Connector with 10/100 Base-T Integrated Magnetics
ANGLES	$\pm 1^\circ$	UNIT: mm	PART NO.: KLK0011GENL
	SCALE: 2/1	SHEET: 2/4	REV: A DWG NO.:

REV.	ECN NO.	DESCRIPTION	DATE	APPD
A	REL		2007-11-30	

REV: A
 TEMP(°C): 25
 HUM(%): 65 RH

SUGGESTED PROFILE OF WAVE SOLDER FOR ROHS PRODUCT

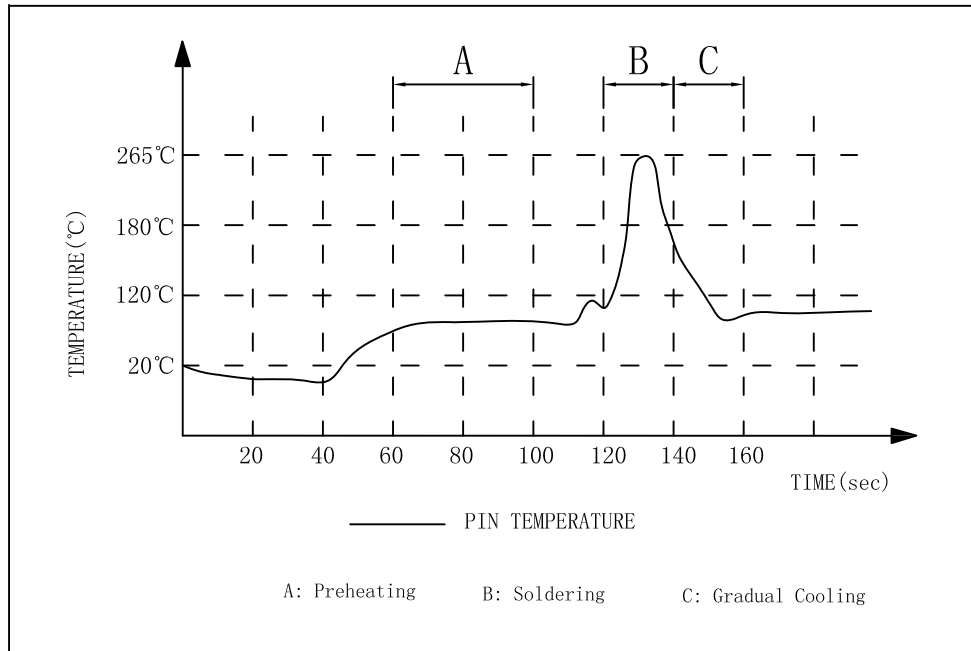

- (1) Tip Temperature: 265°C max
 - (2) Tip Temperature time: 5sec max
- Note: The melting point of Tin: 219°C

X:X ±0.25	APPD:	TITLE: RJ45 Connector with 10/100 Base-T Integrated Magnetics
X:XX ±0.20	CHKD:	
X:XXX ±0.05	DR: SEA	
ANGLES ±1°	UNIT: mm	PART NO.: KLK0011GENL
	SCALE: 2/1	SHEET: 3/4
	REV: A	DWG NO.:

Packaging:

REV.	ECN NO.	DESCRIPTION	DATE	APPD
A	REL		2007-11-30	

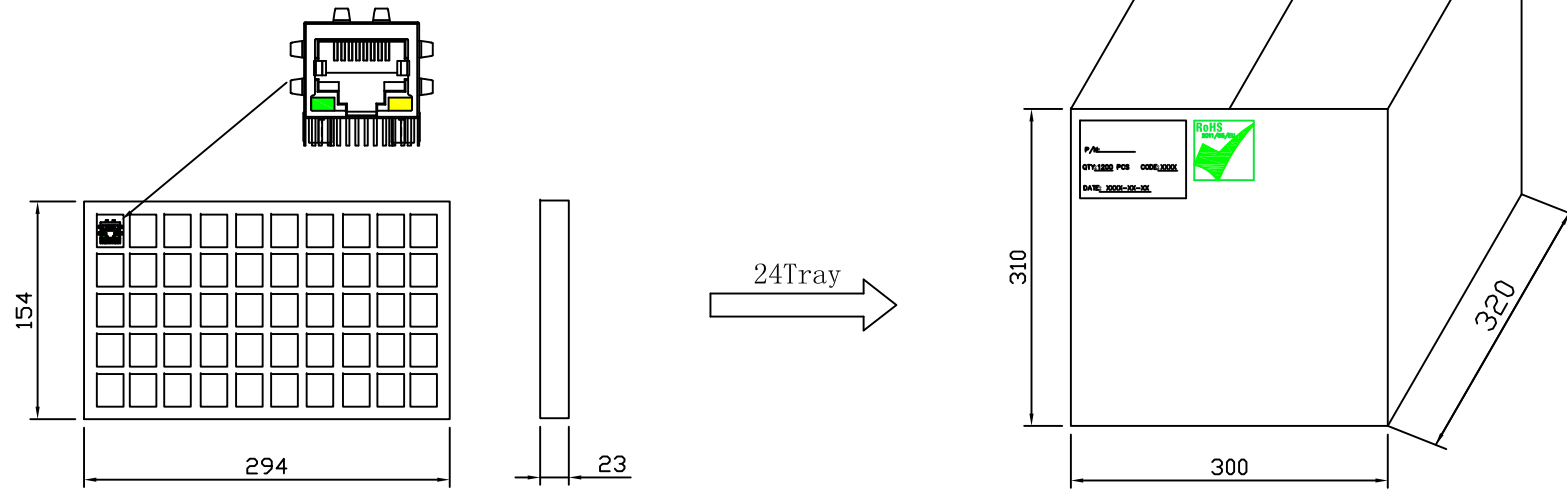

- ◆ Packaging unit: 50pcs/tray
- ◆ Packaging material: PVC
- ◆ Outer carton unit: 1200pcs/24tray/box
- ◆ Net Weight: 8kg
- ◆ Gross Weight: 10kg

X:X	±0.25	APPD:		
X:XX	±0.20	CHKD:		
X:XXX	±0.05	DR: SEA	TITLE: 1*1 21.25mm RJ45 Packing	
ANGLES	±1°	UNIT: mm	PART NO.: KLK0011GENL	
		SCALE: 2/1	SHEET: 4/4	REV: A
		DWG NO.:		