

USBAM-04

P. C. B LAYOUT (对接尺寸)

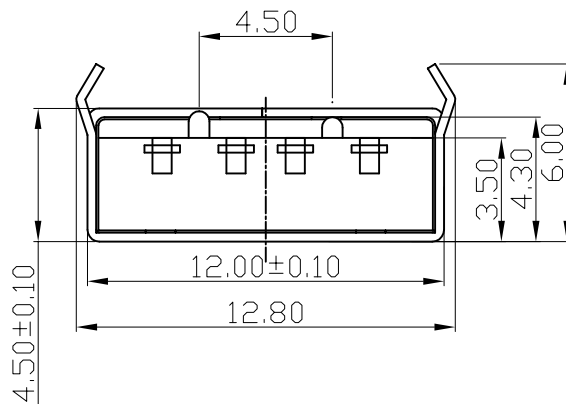
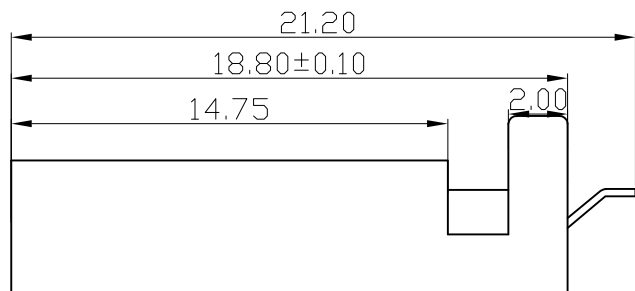
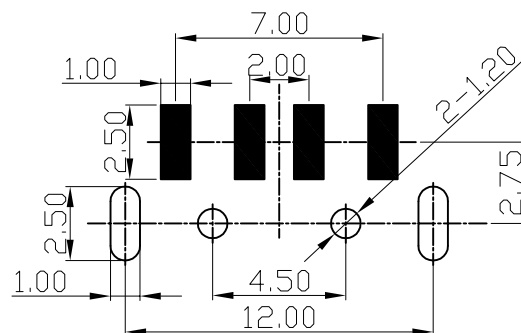
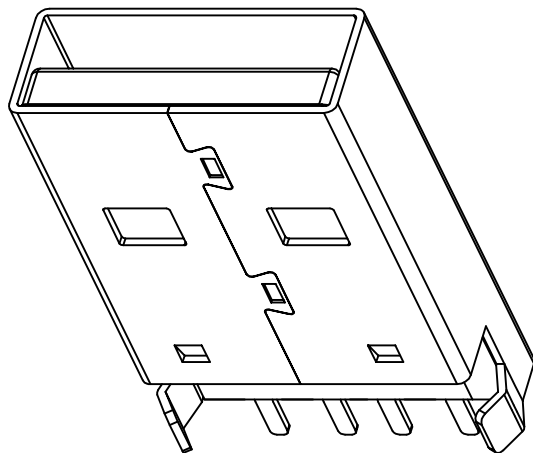
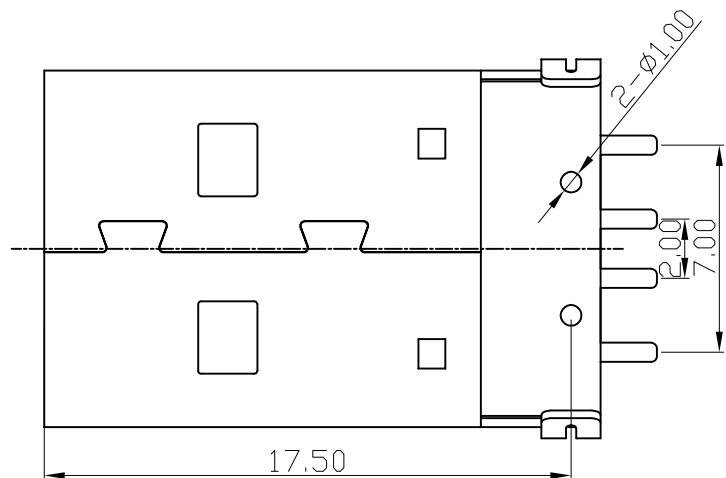

技术要求

1、ELECTRICAL CHARACTERISTICS (电气性能):

- 1.1 Rating (额定值): DC 0.2A 48V
- 1.2 Contact Resistance (接触电阻): $\leq 50m\Omega$
- 1.3 insulation Resistance (绝缘电阻): $\geq 100M\Omega$
- 1.4 Actuating Force (插拔力): 0.7~4kg
- 1.5 Withstand Voltage (耐压): AC500V (50Hz)/min
- 1.6 Life (寿命): 10,000 Cycles MIN (大于10,000次)

2、ELECTRICAL temperature rang (使用温度范围): $-30^{\circ}C \sim +70^{\circ}C$

公差对照表

尺寸范围	公差范围	视角		批准	名称	
0~10	± 0.1	单位				MM
10~20	± 0.2	比例	4:1	设计	型号 USBAM-04	
20~40	± 0.3					编辑日期
40~60	± 0.5					
60~80	± 0.5					
80~100	± 1					
120~140	± 1.5					