石英晶体元件规格书
Quartz crystal specification

提交号(NO): 20200409002

提交日期(DEATE): 2020/04/09

待承认者: 鹏飞电子(香港)有限公司-晶体事业部

制品名称: 石英晶体谐振器

制品料号: SMD-3225-G12QSA-25.0000MHz

送待承认样: /PCS

责任担当		技术担当	
营业担当	余志权	检定担当	李淑梅

承认者: GKK LIMITED

承认结果	资材担当	技术担当	承认担当	承认评定
检定问题点				

ELECTRICAL SPECIFICATIONS

Standard atmospheric conditions

Unless otherwise specified. The standard range of atmospheric conditions for making measurement and tests are as follow:

Ambient temperature : $25 \pm 5^{\circ}\text{C}$

Relative humidity: 40%~70%

If there is no doubt the results, measurement shall be made within the following limits:

Ambient temperature : $25 \pm 1^{\circ}\text{C}$

Relative humidity: 40%~70%

Measure equipment

Electrical characteristics measured by S&A 250B or equivalent.

Crystal cutting type

The crystal is using AT CUT (thickness shear mode)

	Parameters	SYM	Electrical spec.	UNITS	Notes
1	Nominal Frequency	FL	25.000000	MHz	-
2	Oscillation Mode	-	Fund	-	-
3	Load Capacitance	CL	12	pF	-
4	Frequency Tolerance	-	± 20	ppm	MAX
5	Frequency Tolerance	-	± 30	ppm	Over Operating Temp. Range (Reference 25°C)
6	Operating Temperature	-	-40~+85	$^{\circ}\text{C}$	-
7	Aging	-	± 0.5	ppm	1st Year
8	Drive Level	DL	100	μW	-
9	Effective Resistance Rr	Rr	50	Ω	MAX
10	Shunt Capacitance C0	C0	7.0	pF	MAX
11	Motional Capacitance C1	C1	N/A	fF	-
12	Spurious Response	SPDB	-	dB	The spec. is <-3dB(Max.) Within +/-5000ppm of nomial Freq. unless otherwise specified.
13	Insulation Resistance	-	500	M Ω	at DC 100V
14	Storage Temperature Range	-	-55~+125	$^{\circ}\text{C}$	-
15	Others	-	-	-	-

■ **DIMENSION**

1. Crystal enclosure seal : Seam Weld
2. Crystal enclosure medium : Vacuum

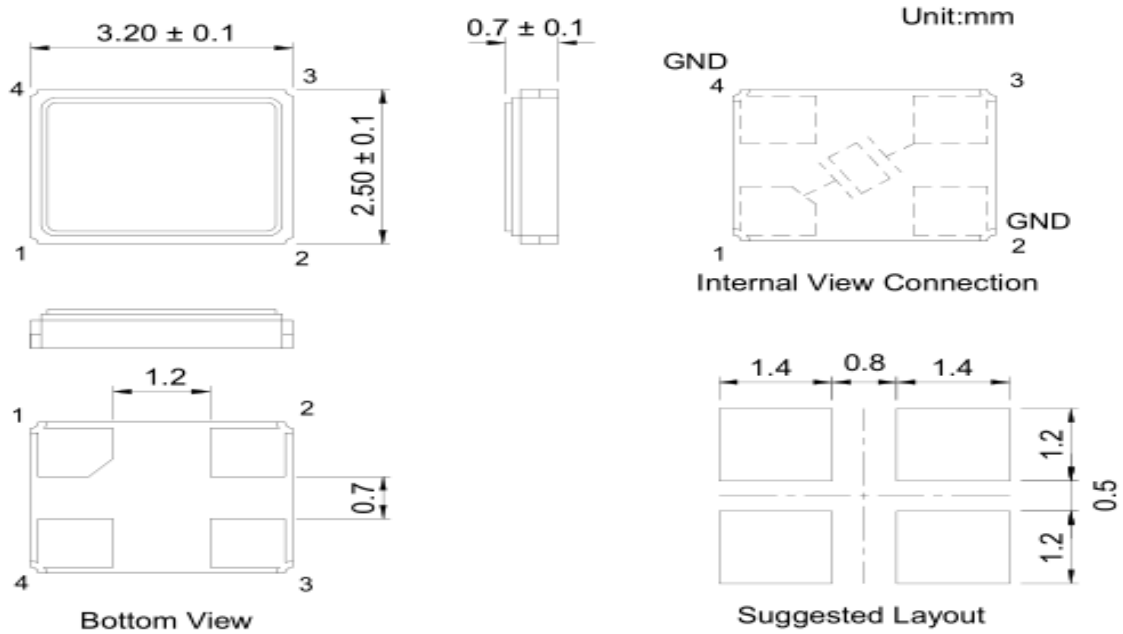

■ **MARKING**

25.000
MHz

Ref. Purchase Specification

■ **SHELF LIFE & STORAGE CONDITIONS**

No shipment is allowed by manufactured over 1 year .
Storage Conditions:

Temp.	Humidity
25 ± 3°C	40~60%

■ **SUGGESTED REFLOW PROFILE**

Total time : 360sec.Max.

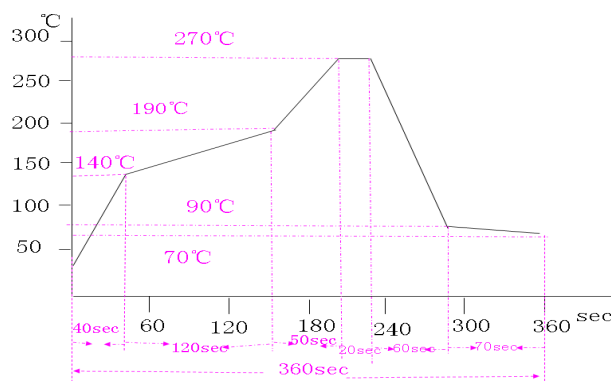

■ **STRUCTURE ILLUSTRATION**

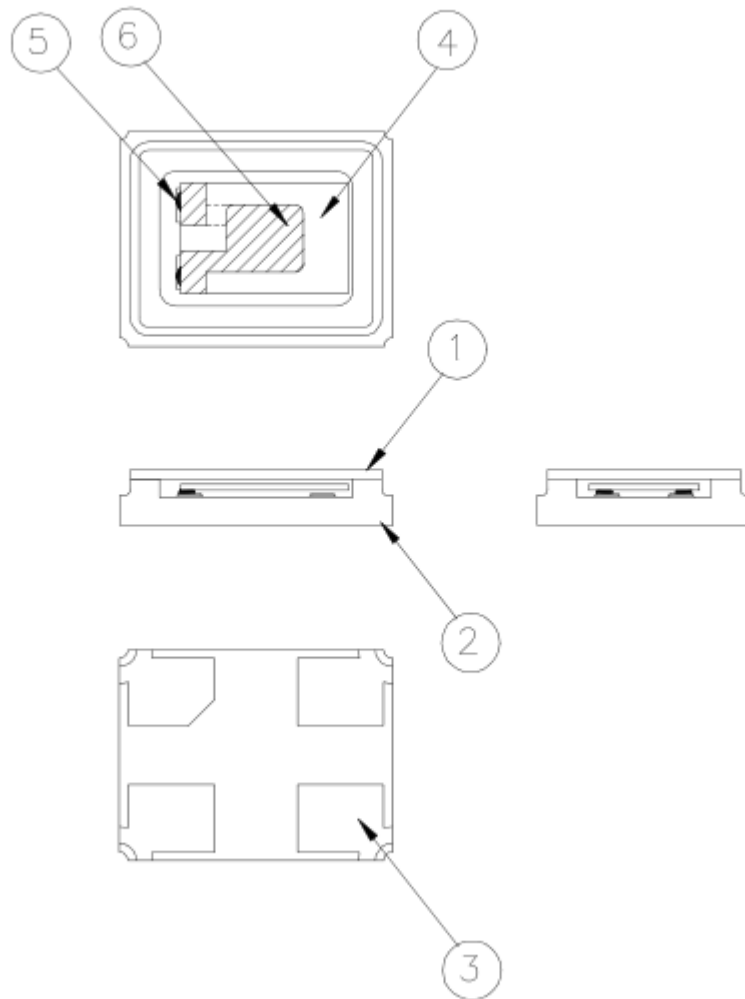

NO	COMPONENTS	MATERIALS	QTY	FINISH/SPECIFICATIONS
1	Cap	Metal (Fe)	1	-
2	Base	Ceramic	1	Color black
3	PAD	Au	4	Tungsten metalize +Ni plating +Au plating
4	Crystal blank	SiO ₂	1	-
5	Conductive adhesive	Ag	4	Epoxy resin
6	Electrode	Ag + Cr	2	-

- **PACKING: (EIA-481-2)**
 - Shear strength between cover and carrier tape should be 30-100g.
 - Carrier tape should be folded over three times with no break at all.

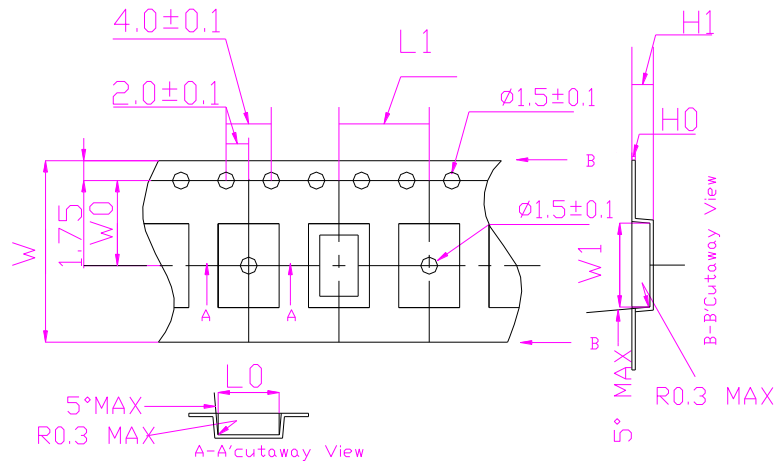

	Dimension Tolerance (mm)						
	W	W0	W1	L0	L1	H0	H1
3225-8	8.0±0.3	3.5±0.1	3.6±0.1	2.9±0.1	4.0±0.1	0.3±0.05	1.5±0.1

REMARK:

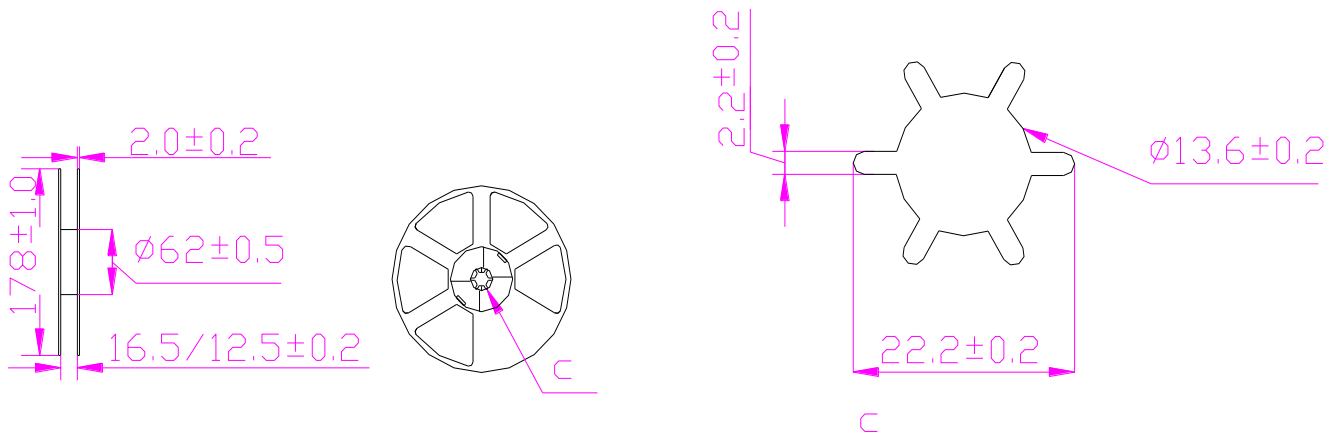
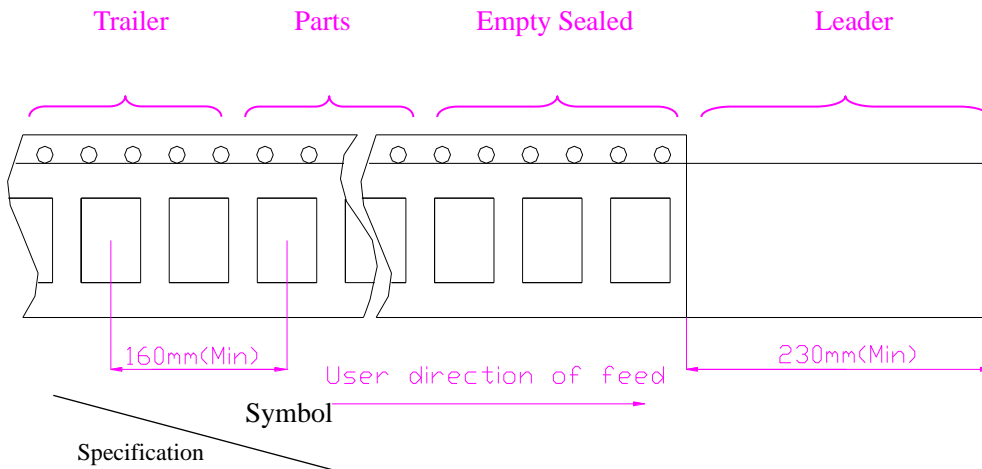

Unit : mm

Standard Reel Quantity is 3,000 pcs per reel.

■ RELIABILITY SPECIFICATIONS

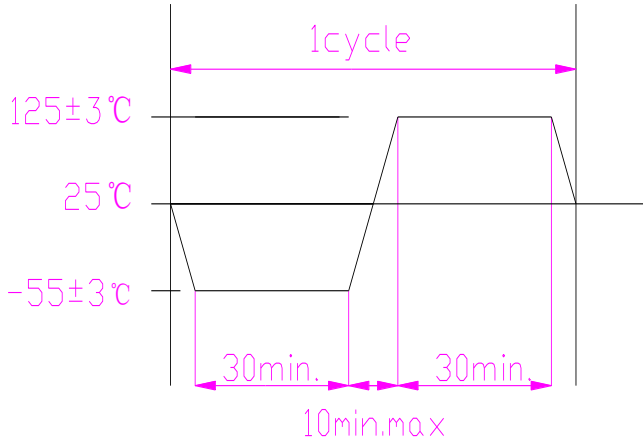
NO	Test Item	Test Methods	Ref.Doc
1	Drop test	75 cm height, fall freely onto stainless plate 3times.	-
2	Mechanical Shock	Device are shocked to half sine wave (1000G) three mutually pendicular axes each 3 times.0.5sec.duration time.	-
3	Vibration	Frequency range 10~2000Hz Amplitude 1.52mm Sweep time 20 minute Pendicular axes each test time 4 hours (Total test time 12 hours)	-
4	Solderability	Temperature 255°C ± 5°C Immersing depth 0.5mm minimum Immersion time 10 ± 0.5seconds Flux Rosin resin methyl alcohol Solvent (1:4)	-
5	Resistance To Soldering Heat	Pre-heat temperature 125°C Pre-heat time 60~120sec. Test temperature 260 ± 5°C Test time 5 ± 1sec.	-
6	High Temp. Storage	+125°C ± 2°C for 1000 ± 12hours	-
7	Low temp. Storage	-40°C ± 2°C for 1000 ± 12hours	-
8	Thermal Cycles	Total 100 cycles of the following temperature cycle 	-

环境管理物质使用规范

Specification of the environment-related substances

范围 Range	产品 Products	包材 Packing Material	Test Method
禁限物质 Banned Substances	最高含量 Maximum concentration ppm(mg/kg)	最高含量 Maximum concentration ppm(mg/kg)	
1.镉及镉化合物 Cadmium and cadmium compounds	5	5	ICP-AES as per EN1122, method B2001 or other acid digestion.
2.铅及铅化合物 Lead and lead compounds	40	100	ICP-AES after as per EPA 3050B or other acid digestion.
3.汞及汞化合物 Mercury and mercury compounds	5	5	ICP-AES after as per EPA 3052 or other acid digestion.
4.六价铬化合物 Hexavalent-Chromium VI (Cr ⁺⁶)	10	10	As per US EPA 7196A and US EPA 3060A.
5.聚溴联苯 PBB Polybrominated biphenyls	5	5	With reference to USEPA 3540 or USEPA3550. Analysis was performed by LPLC/DAD, LC/MS or GC/MS. (prohibited by 2002/95/EC (RoHS),83/261/EEC, and76/769/EEC)
6.聚溴二苯醚 PBDE Polybrominated diphenyl ethers	5	5	With reference to USEPA3540or USEPA3550. Analysis was performed by HPLC/DAD LC/MS or GC/MS.(prohibited by 2002/95/EC(RoHS), 83/264/EEC, and 76/769/EEC)
7.多氯联苯 (PCB) Polychlorinated biphenyl	5	5	
8.多氯化萘 (PCN) Polychlorinated naphthalene	5	5	
9.氯代烷烃 (CP) Chlorinated paraffin	5	5	
10.其他有机氯化物 Other chlorinated organic compounds	5	5	
11.其他有机溴化合物 Other brominated organic compounds	5	5	
12.有机锡化合物 (三丁基锡化合物,三苯基锡化合物) Organic tin compounds (Tributyl tin category & Triphenyl tin category)	5	5	
13.石棉 Asbestos	5	5	
14.偶氮化合物 Azo compounds	5	5	
15.甲醛 Formaldehyde	5	5	
16.聚氯乙烯(PVC)以及聚氯乙烯混合物 Polyvinyl chloride (PVC) and PVC blends	No detect	No detect	
17.包装材料中重金属(汞、镉、六价铬、铅、PBB、PBDE)之总量 Heavy metals (mercury, cadmium, lead, Cr ⁺⁶ ,PBB and PBDE) in packing materials	N/A	<100	

Lead Free Products are “Directive 2002/95/EC of The European Parliament of 27 January 2003 on the restriction of certain hazardous substances (RoHS) in electrical and electronic equipment” and Sony SS-00259 Compliant.