

Front view
Scale: 1:1

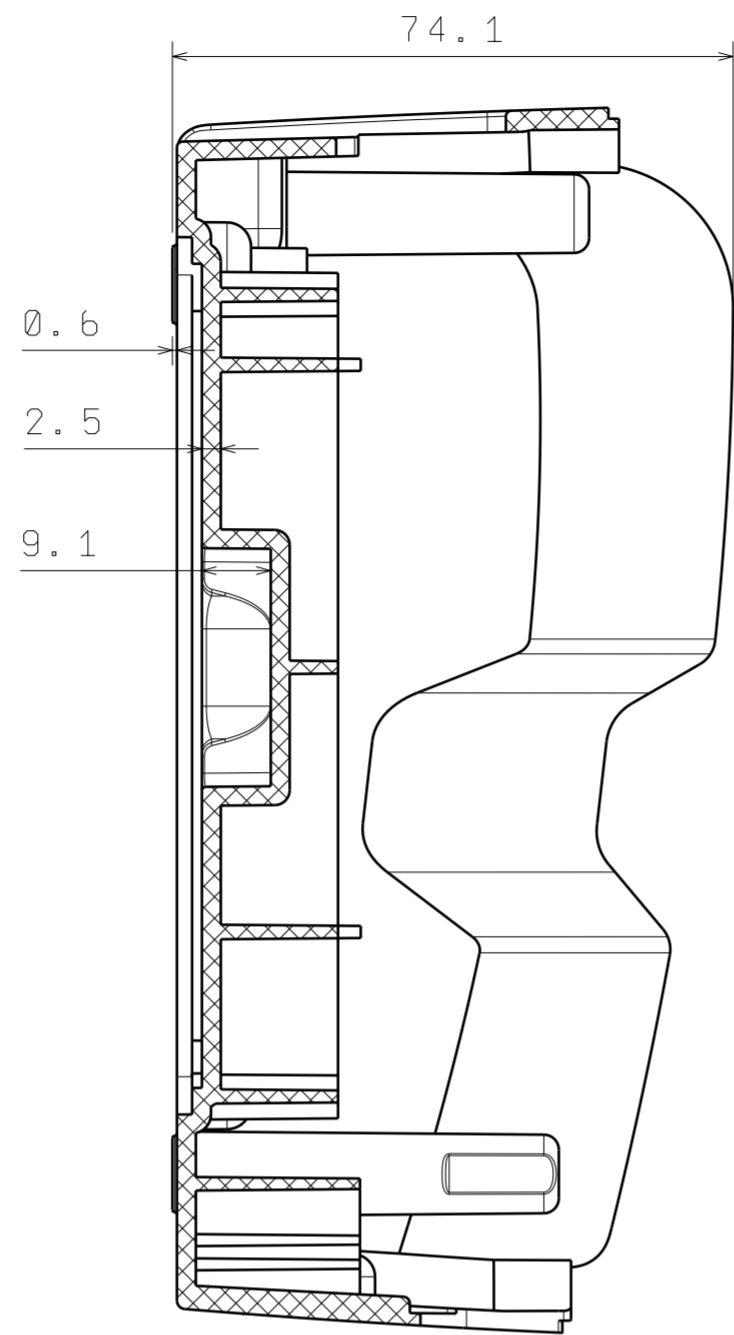

Section view A-A
Scale: 1:1

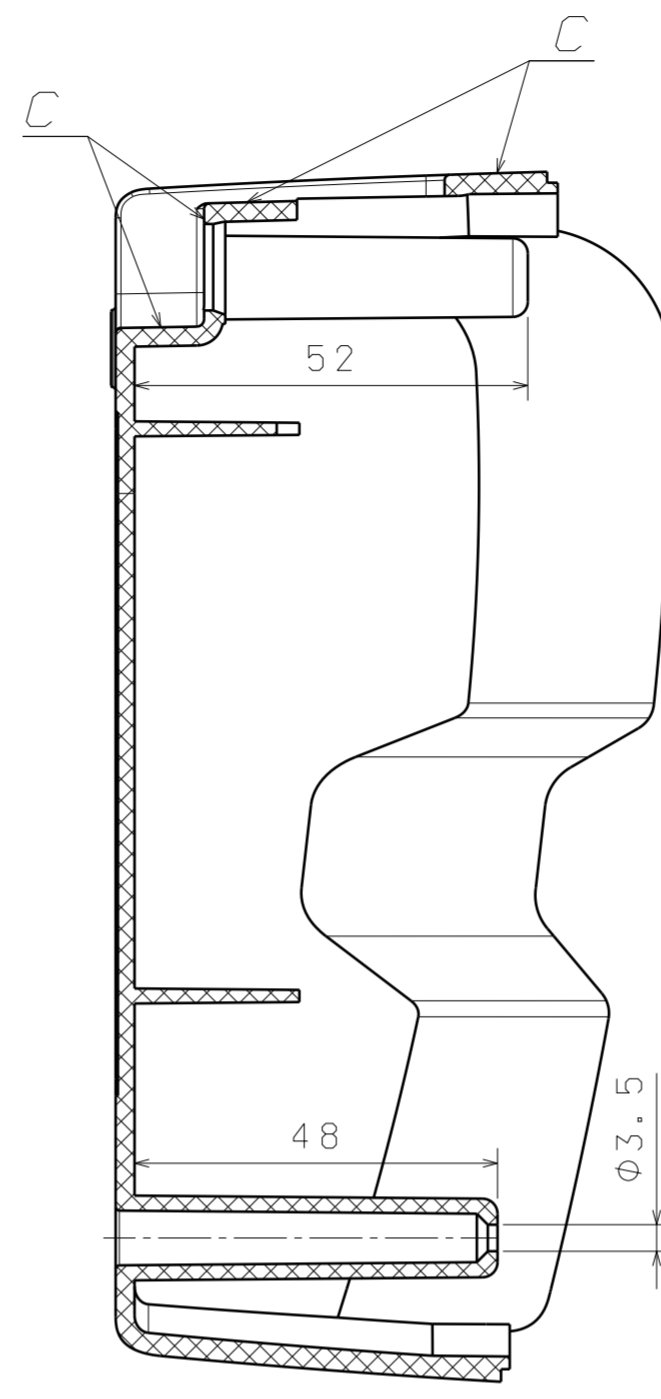

Section view B-B
Scale: 1:1

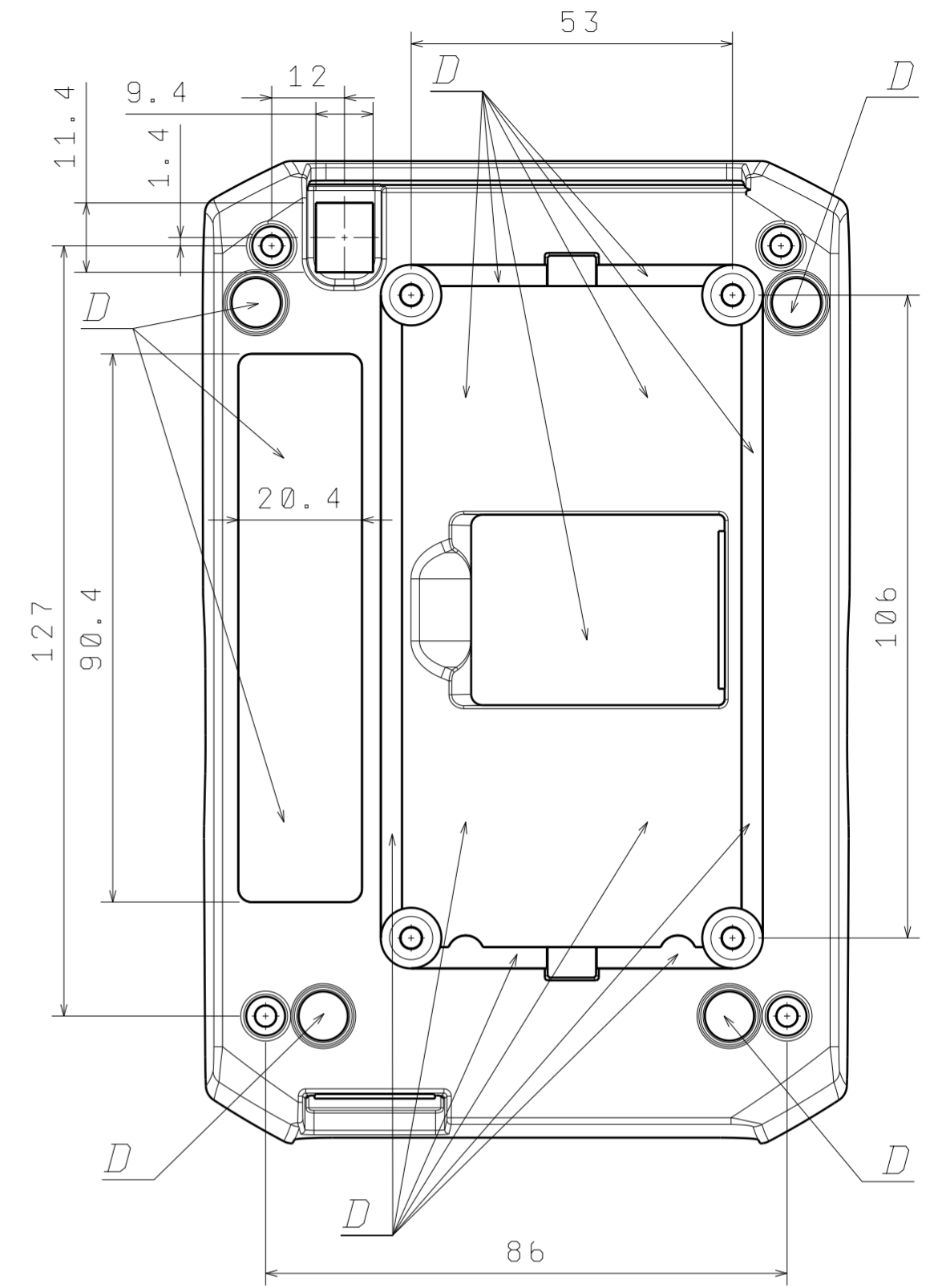

Back view
Scale: 1:1

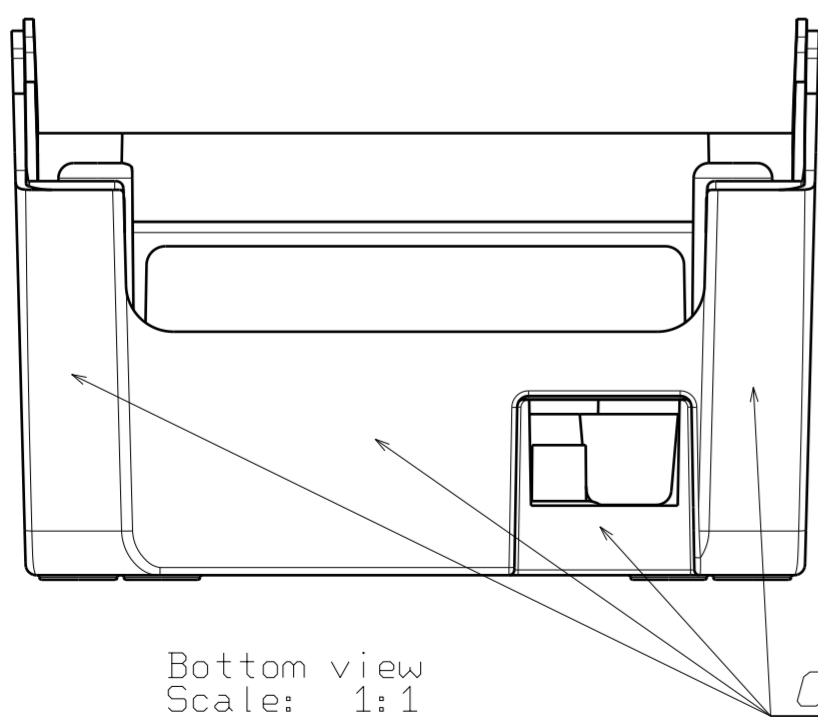

Bottom view
Scale: 1:1

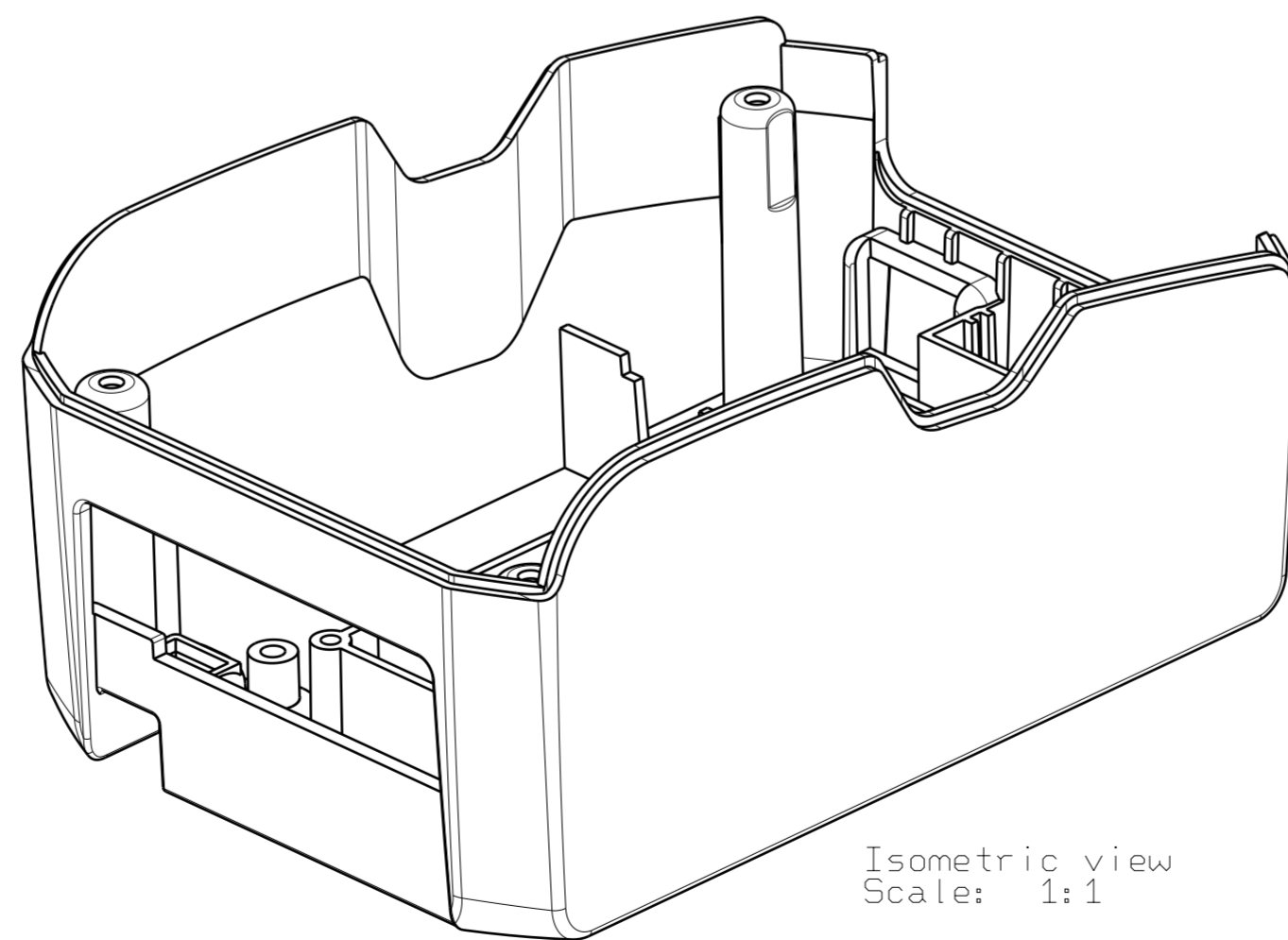

Isometric view
Scale: 1:1

1. All dimensions and surface shapes from the 3D model SMM16064.00.02_BOTTOM_PART_(Rev.).stp
2. Here the basic dimensions are specified only.
3. Other tolerances : H12, h12, $\pm IT/2$.
4. Material - ABS, color - RAL 7021.
5. The texture of the surfaces "C" must be the same as of the sample MT 9051.
6. The quality of surfaces "D" - polish.
7. All visible surfaces must be without any defects such as scratches, pulling-downs and bubbles.

This drawing is our property. It can't be reproduced or communicated without our written agreement.		SHTRIH-M		
DRAWN BY		DRAWING TITLE		
A. Dubovitski		BOTTOM PART		
CHECKED BY	DATE	SIZE	DRAWING NUMBER	REV
	29.08.2016	A2	SMM16064.00.02	R1
DESIGNED BY	DATE	SCALE	WEIGHT (kg)	SHEET
		1:1		1/1