

**Circuit Diagram**

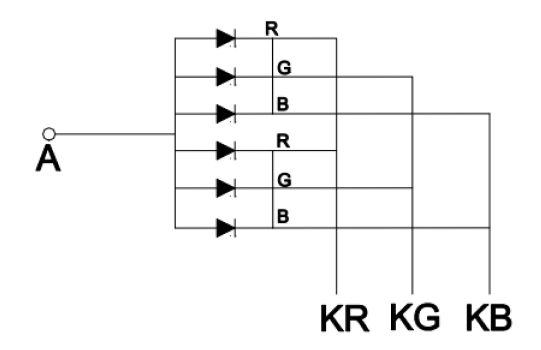

**3pcs RGB SMD LED Corlor:RGB  
(Test Datasheet on led backlight)**

Item	Symbol	MIN.	TYP.	MAX.	Unit	(Ta=25°C) Condition
Forward Voltage	VfR	1.9	2.1	2.2	V	If=30mA
	VfG	2.8	3.0	3.2	V	
	VfB	2.8	3.0	3.2	V	
Dominant Wave Length	λD				nm	
Luminance	Lv				cd/m <sup>2</sup>	
Uniformity	Avg	75			%	
Reverse Current (Per LED)	Ir			10	uA	Vr= 5.0 V

- \* - dimensions for information.
- All sizes and surfaces forms should coincide with the 3D model TNMM24001.011.010\_Lightboard\_.stp.
- RoHS compliance (RoHS).
- Single LGP.
- Operating Temperature: -20°C~70°C.
- Storage Temperature: -25°C~75°C.
- Test Instrument: BM-7.
- Test Distance: 500mm/
- Aperture Diameter: Ø7.7.

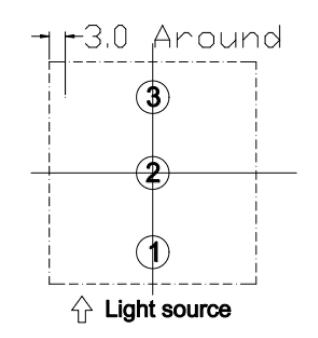

Разраб. A.Kharitonov	Пров.	Дата утв.	Дата	Дата 23.01.2025
			<b>Lightboard</b>	
			TNMM24001.011.010	Редакция R0